

Order no. 888/14000

Tandem three-way tipper and low loader, with inserted aluminium loading rails

Weights:	Total weight of which drawbar load Payload in standard equipment approx. empty weight approx.	14000 kg 1000 kg 11000 kg 3000 kg
Dimensions:	Loading dimension inside approx. (length x width) Dropside height approx. loading height unloaded approx. drawbar length approx. coupling height unloaded approx. overall dimensions length x width approx.	4500 x 2420 mm 450 mm 1100 mm 1800 mm max. approx. 1020 mm 6550 x 2550 mm
Ramps:	Length approx. width approx. drive-on angle approx.	3500 mm 400 mm 17° Degree
Hydraulics:	Tilt angle rear/side approx. oil requirement approx.	45°/45° Degree 14,5 litres
Tyres:	Size	285/70 R 19.5 4-times with valve sensors for TPMS

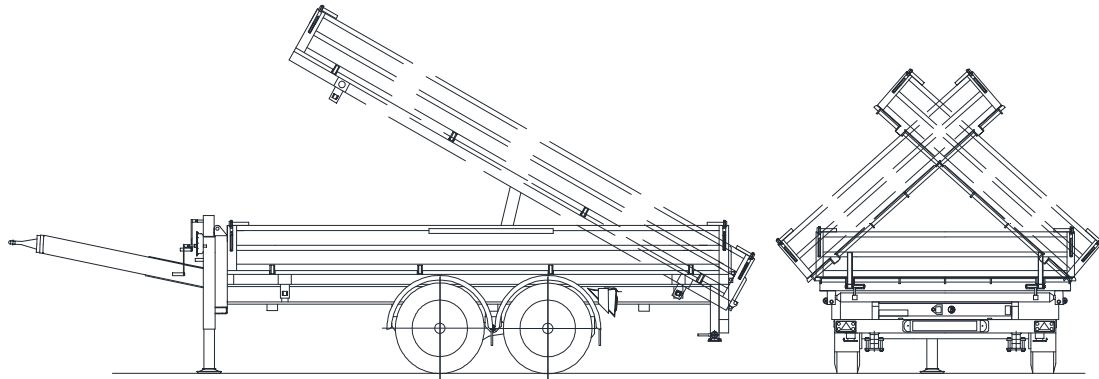

Equipped as standard with:

- HARDOX floor grade 450
- EBS brake system with automatic parking brake (TEM) and spring-loaded brake
- Tyre pressure monitoring system (RDK/TPMS)
- Aluminium loading rails with 9t load capacity, inserted under the cargo bed, with locking flap (lockable)
- 3 pairs of lashing points on each side of the cargo bed
- Lighting built into the underride guard
- Painted in two colours in the RAL shade of your choice

Technical description

Order no. 888/14000

Tandem three-way tipper and low loader, with inserted aluminium loading rails

- Axles:** Gigant high-speed axles with S-cam brake and maintenance-free parabolic spring unit with load equalisation
- Brake system:** **EBS** air brake system (multi-voltage with 24V plug-in connection in accordance with ISO 7638-01) with **TEM** (automatic parking brake), test connections, connecting hoses with swap-proof coupling heads and **spring-loaded brake**
- Pulling device:** Drawbar made of hot-finished S355 grade hollow section, infinitely height-adjustable via spindle winch, with lorry DIN drawbar eye (40 mm), height adjustable from approx. 0.72 m to 1.02 m
- Chassis:** Robust welded construction made of sectional steel (including IPE and UNP profiles, grade S355), electrically welded, reinforced underride guard in accordance with ECE R58-03
- Structure:** Bridge floor **made of one sheet of HARDOX® steel grade 450**; stable tilting frame with spherical half shells (noise-damped); laser-welded steel drop sides made of fine-grained steel all round and hinged at the sides with strong hinges; swinging rear drop side with central locking; plug-in corner posts at the rear; 1 pair of lashing recesses (2500daN) incorporated in the centre of the floor, lashing hooks (5000daN) welded onto the front corners, lashing rings (5000daN) welded onto the rear corners
- Hydraulics:** Motor-hydraulic; with a heavy 4-stage tilt cylinder and lift limiter; plug-in coupling as single-circuit connection
- Support:** 10-tonne geared support winch with load and high-speed gear at the front; 2 telescopic parking supports with support leg safety device at the rear
- Ramps:** Aluminium loading rails, slide in under the loading area; extendable on rollers; can be closed with a sturdy steel flap; **load capacity/pair 9000kg** (with 2m wheelbase load); weight approx. 56 kg per piece
- Electrics:** Splash-proof lighting in accordance with ECE Directive ECE-R 48.06 (multi-chamber light, protected in the underride guard, **LED side marker**, clearance and licence plate lights); 24 V, 7+7 or 15-pin as specified
- Paintwork:** Steel parts steel grit blasted, pre-treatment with iron phosphating; corrosion-inhibiting zinc phosphate primer, electrostatic painting in two acrylic RAL colours (high-solid) as specified, subsequent cavity sealing with preservative wax
- Accessories:** **Tyre pressure monitoring system (TPMS)**, 2 brake pads with holder, anti-spray mats, full mudguards, EC type approval, registration papers, contour markings in accordance with ECE R 104